



NuFiber™ panels

Rev. 08 9/15

Please Read Disclaimers:

PLEASE READ ALL INSTRUCTIONS BEFORE BEGINNING INSTALLATION!!

These guidelines are provided in good faith to help prevent any problems caused by common errors in installation. The manufacturer and/or distributor of this product shall not be held responsible for installation actions taken or not taken. There are many details of installation that are assumed to be general construction knowledge to experienced installers; which are not included in these instructions. These installation guidelines are intended to be strictly recommendations and are NOT to serve as a step-by-step, fail-safe installation checklist. Selection of an experienced installer is the sole responsibility of the project owner and architect.

Nudo Products, Inc. does not accept any responsibility for job failure resulting from or associated with improper site environmental conditions.

Uses & Applications:

NuFiber panels with factory bonded substrates of wood, drywall, extruded foam or gypsum may be applied to wood or metal studs (proper gauge studs must be used for panel selected), furring strips, solid walls, ceiling joists are used as dividers. Install a vapor barrier behind panel when installing in high moisture areas or use panels with factory applied vapor barrier. Proper selection of substrate is also required in high moisture areas in both interior and exterior applications.

Note: Due to the nature of wood components parts used in the fabrication of NuFiber, some panels may have moderate bowing prior to installation.

Safety Instructions:

When cutting or drilling, always wear protective glasses or goggles and a face mask which covers the face and mouth. Itching due to fibers may be avoided by the use of barrier creams on exposed skin areas.

Tools Needed

- Power saws with carbide tipped saw blades
- Power drill with carbide bits
- Pencil

Materials Needed

- NuFiber panels
- Non-abrasive cleaner, soap and water, mineral spirits, for use in clean-up
- Rags
- Personal protection equipment (goggles & mask)
- Tape measure
- Saw horses
- Painter's tape
- Plywood larger than panels
- Ladders or scaffolding



Storage and Preparation

All NuFiber panels should be stored indoors in a dry area. Do not store panels outdoors. Panels should be unwrapped and removed from skid and stacked on a flat, dry surface. Do not stand panels on edge or stack on fresh concrete floor or any other surface that emits moisture. Panel should be acclimated to temperature and humidity of space for at least 24 hours prior to installation. Ideally, the room temperature and humidity during acclimation and installation should be the same as the final operation conditions. Optimum storage conditions are 60°F (16°C) to 75°F (24°C) and 35% to 55% relative humidity.

Expansion & Contraction

NuFiber panels will expand and contract. Always allow 1/8" gap at ceiling, base and gap between panels. If face mounted moldings (T-Bar, Batten, 2-Piece Division bar, etc...) allow 1/8 gap between panels (see diagram). Allow more space for expansion and contraction of panels longer than 8' and in area(s) where high fluctuation in temperature and humidity occur and when installing around pipes, conduits, electrical outlets, etc.

Molding & Sealants

Use of moldings and silicone sealant with panels having appropriate substrates is recommended to achieve a moisture resistant installation. Cut molding to size and place silicone sealant into channel of molding during installation. Place molding on panel before fastening and place small amount of silicone into hold before fastening, if required see below diagram.



In high moisture and frequent wash down area(s), silicone should be placed between molding and floor to prevent moisture from penetrating back of panel substrate. If no moldings are used, silicone sealant should be placed in gaps at floor, ceiling and between panels for moisture resistant installation. Remove excess silicone during installation or trim off silicone after it has cured.

Caution: Failure to use moldings and sealant may cause panel deterioration. In high moisture areas or in standing water, edge swelling and moisture absorption by substrate will occur if appropriate sealants are not used properly. Install a vapor barrier behind panel installation in high moisture areas or use panel with a factory applied vapor barrier. Proper selection of substrate is also required in high moisture areas. This requirement is necessary for either interior or exterior installations.

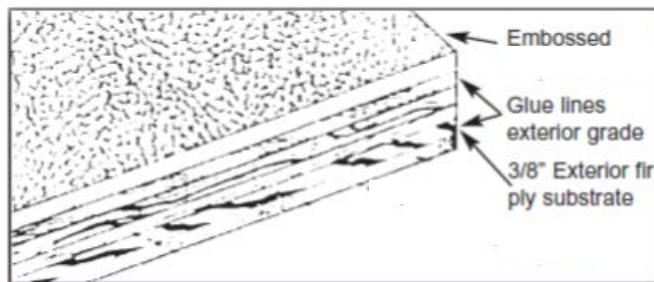

NUDO

Nudo Products, Inc.
1500 Taylor Avenue
Springfield, IL 62703
Phone 1.800.826.4132 * 1.217.528.5636
Fax 1.217.528.8722

Form 6001.NF Rev. 08/9/15
Info@nudo.com
www.nudo.com



Fasteners

All panels should be installed with non-corroding fasteners. Plastic pin rivets, chrome pin rivets, one piece nylon rivets, stainless nails, one stepper fasteners or screws are recommended. See below. Fasteners should be installed to fit snug but should not be over-tightened. Always select proper fasteners for installation.

Plastic pin rivet fastens panel to wood, metal, drywall, concrete, insulation materials, etc. See diagram below:

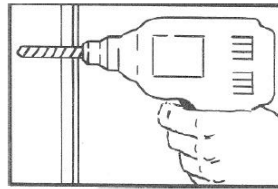

Easy to use Drill a hole (.257"-F Bit)

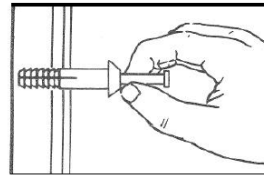

Remove dust and filings from the hole. Insert rivet.

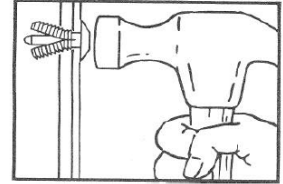

Hit the pin. The shank expands into or behind material for a tight, secure grip

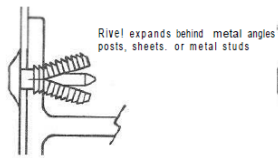

Rivet expands behind metal angles, posts, sheets, or metal studs

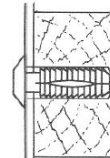
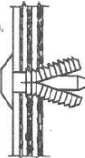

Rivet expands into solid furring strips, studs, substrates of brick block, concrete, drywall

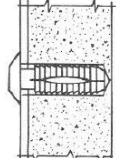

Note: If pin in rivet does not drive flush when fastening into solid materials and applications where expansion may be restricted, larger hole is required, use .261" - G bit.



Chrome pin rivet has high shear strength but should be used in low moisture areas. Installation is the same as plastic pin rivet above.



One piece-nylon rivet fastens panels to any wood substrate or wood stud. See diagram below:

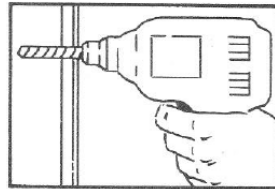

Easy to use. Drill a hole (.281"-K Bit)

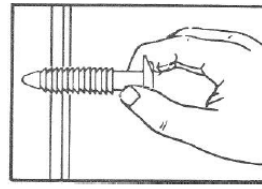

Remove dust and filings from the hole. Insert rivet.

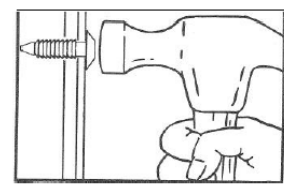

Drive rivet flush

Adhesives

The use of adhesive when installing panels is recommended along with fasteners. Titebond adhesives are recommended.

For best installation, adhesive should be used on studs in conjunction with fasteners when installing NuFiber panel. See below diagram.

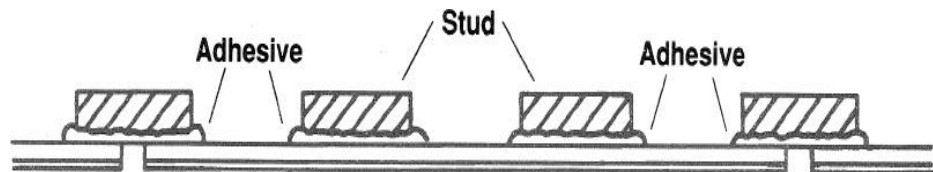

NUDO

Nudo Products, Inc.
1500 Taylor Avenue
Springfield, IL 62703
Phone 1.800.826.4132 * 1.217.528.5636
Fax 1.217.528.8722

Form 6001.NF Rev. 08/9/15
Info@nudo.com
www.nudo.com

Fastener Layout

1. Pre-Fit each panel before fastening and cut panel if required to center on studs for proper fastening.
2. Apply vapor barrier behind panel installation if required. Always use vapor barrier in high moisture areas.
3. Stud walls 16"-24" on center (o/c) use minimum 3/8" panel substrate. Ceiling joists 16" o/c use minimum 3/8" panel substrate; 24" o/c joists use minimum 1/2"-5/8" panel substrate.
4. Fastener frequency may vary with thickness of panel substrate.
5. On wood studs 16" o/c use stainless nails on edges every 8" o/c staggered on opposite panel edges. On center studs use plastic rivets every 24" o/c. For 24" o/c studs refer to fastening pattern diagram.
6. On metal studs 16" o/c use stainless screws on edges every 8" o/c staggered on opposite panel edges. On center studs use plastic pin rivet every 24" o/c. For 24" o/c studs see diagram B.
7. If studs run horizontal, plastic or other types of fasteners may be used for complete installation of panels. Fastener frequency same as in No. 5 or 6. See diagram A.
8. If only plastic fasteners are used for installation of panels, fasteners should be placed at 12" o/c on edges and 16" o/c on center studs.
9. Some types of panels may be compatible for commercial installations using fasteners on edges (8" o/c) and adhesive on center stud(s). The results in a panel installation with no visible fasteners. See diagram A.
10. Stud walls must be supported on opposite side of panel installation and proper gauge stud must be used for panel selected, prevent deflection on wall system.

Note: If panel deflects from center stud(s) after this type of installation, fasteners will be required on center stud(s). The 1/8" edge separation rule may make it necessary to trim panel width or length occasionally as installation progresses along a long wall with support members evenly spaced at 16" or 24".

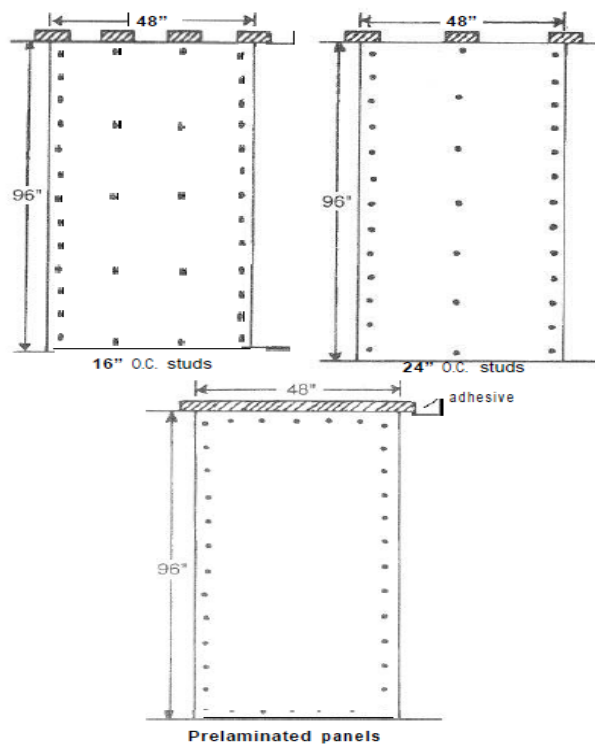

Mechanical Fastening Pattern

NUDO

Nudo Products, Inc.
 1500 Taylor Avenue
 Springfield, IL 62703
 Phone 1.800.826.4132 * 1.217.528.5636
 Fax 1.217.528.8722

Form 6001.NF Rev. 08/9/15
Info@nudo.com
www.nudo.com

Top View of Panel Installation

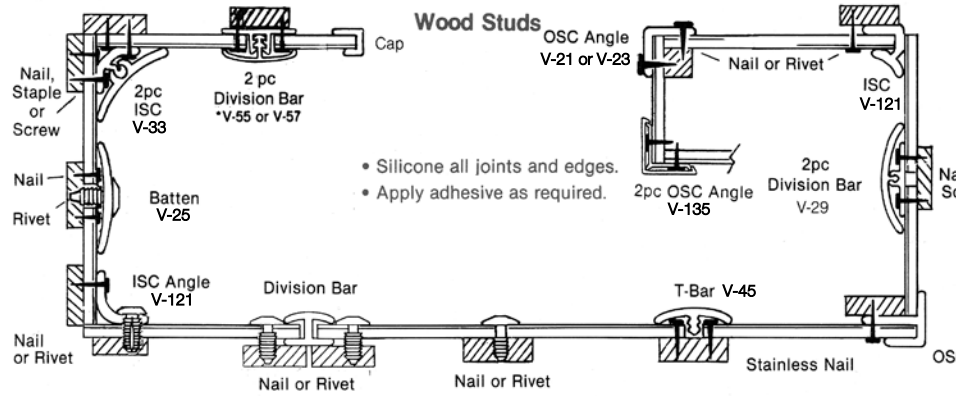

Solid Wall Installation Diagram A

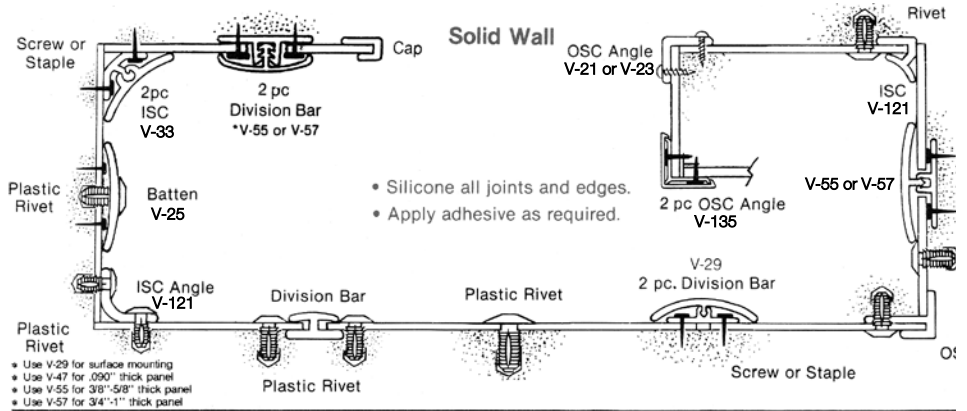

Metal Stud Installation Diagram B

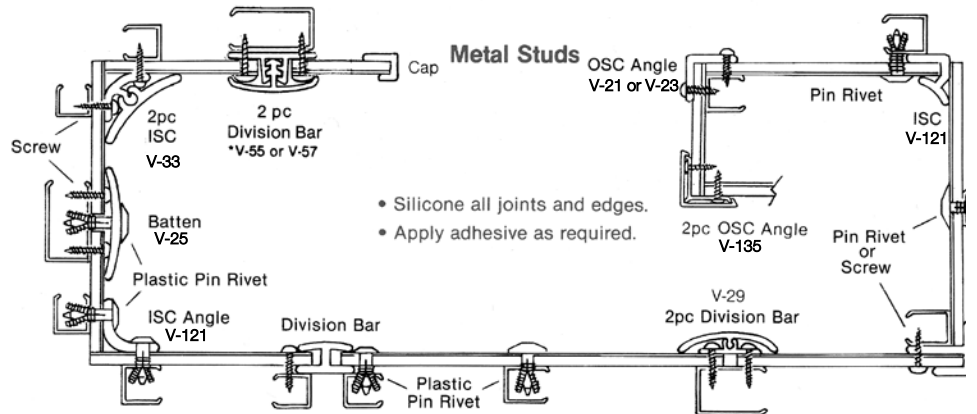

Installation Reminders

1. Follow safety and fire guidelines during installation and use of panels. Compliance with local building codes is recommended.
2. First panel installed should be set true with plumb line. Check plumb line during installation.
3. Pre-condition panels prior to installation and allow for expansion and contraction during installation.
4. Use moldings, silicone, fasteners, and adhesive with panels for best installation.
5. Remove excess silicone during installation or trim after silicone is cured.

6. Place molding on panels, if required before fastening panels (ie. CAP, ISC, OSC, etc.).
7. Cut moldings as needed. For example, division bar may need to be cut in accommodate a ceiling or base cove.
8. Cut panels, if required, for proper installation.
9. Use hold-down clips if panels are used in a suspended ceiling.
10. Span studs or joists only with proper thickness of panel.
11. Clean panels, if required, after installation.

Cleaning Instructions

NuFiber panels are designed for minimum care and maintenance. When cleaning panels they should be washed with a light detergent. Panels may also be cleaning with steam, high pressure sprayers or soap and water.

A 5% or 10% Tri Sodium Phosphate water solutions may also be used to clean panels. Rinse thoroughly after applying. Hard water deposits may be cleaned with a 10% solution of Acetic Acid in cold water. Rinse thoroughly after applying. It is strongly recommended not to use abrasive cleaners when cleaning panels. Adhesive can be removed from panels surface by using mineral spirits or equivalent solvent based cleaners.

Note: NuFiber and components made of aluminum, polystyrene foan, vinyl and wood may be combustibile and accordingly should be used in compliance with local codes and insurance regulations.

